



Self-Contained Carpet Extractor

ACHIEVER 80 ACHIEVER 110

INTRODUCTION

OPERATING & MAINTENANCE INSTRUCTIONS

READ THIS BOOK

This operator's book has important information for the use and safe operation of this machine. Read this book carefully before starting the machine. Keep this book and tell all operators to read the book. If you do not follow the instructions, you can cause an injury or damage equipment, furniture or buildings.

For additional information refer to the Triple S website www.triple-s.com or write to:

Triple S
2 Executive Park Drive
Billerica, MA 01862

Carefully inspect all components to ensure that there is no concealed freight damage. If such damage is discovered, file a "CONCEALED DAMAGE REPORT" immediately with the delivering carrier.

The contents of this manual are based on the latest product information available at the time of publication. Triple S reserves the right to make changes or improvements to its machines without notice.

FOR YOUR CONVENIENCE, RECORD THIS IMPORTANT INFORMATION:

MODEL _____

SERIAL NUMBER _____

PART NUMBER _____

DATE PURCHASED _____

INTRODUCTION

The **SSS ACHIEVER Machine** is a fully self-contained, portable carpet extractor system and is intended for commercial use. A wand with external vacuum and solution hoses are not necessary with your ACHIEVER machine, but available.

The **ACHIEVER 80/110** has a 100 psi solution pump and a four (4) jet spraying system located on the bottom side of the machine to apply solution to the carpet.

A rotating brush is driven by a cogged belt system at approximately 1200 RPM's. This brush provides a very aggressive agitation of the solution into the carpet fibers to loosen ground-in dirt. The chevron pattern of the brush bristles channels the dirty water to the center of the aluminum vacuum head for better extraction.

With a heavy duty three-stage vacuum motor, capable of 137 inches of water lift, your ACHIEVER machine extracts virtually all of the dirty solution from the carpet fibers, which dramatically reduces drying time.

The ACHIEVER 80/110 machines are very "user friendly" machines. All controls are located at the top of the handle grips, literally at your fingertips. The recovery tank drain valve is located high enough for the recovered solution to be drained into a five (5) gallon bucket or bathroom toilet.

ACHIEVER 80/110 machines are balanced on large 10" diameter wheels for ease of operation and transporting. The machines can be rotated 360° with relative ease, even when filled with solution.

The location of the wheel axle and the large diameter wheels allows for easy transporting up and down steps when empty. It is not recommended these machines be transported up or down steps while containing any liquid in either the solution or recovery tanks.

Grounding Instructions

This machine must be grounded. If it should malfunction or break down, grounding provides a path of least resistance for electric current to reduce the risk of electric shock. This machine is equipped with a cord having an equipment-grounding conductor and grounding plug. The plug must be inserted into an appropriate outlet that is properly installed and grounded in accordance with all local codes and ordinances.

WARNING - Improper connection of the equipment-grounding conductor can result in a risk of electric shock. Check with a qualified electrician or service person if you are in doubt as to whether the outlet is properly grounded. Do not modify the plug provided with the machine - if it will not fit the outlet, have a proper outlet installed by a qualified electrician.

This machine is for use on a nominal 120-volt circuit, and has a grounded plug that looks like the plug illustrated in figure A. A temporary adapter that looks like the adapter illustrated in figures B and C may be used to connect this plug to a 2-pole receptacle as shown in figure B if a properly grounded outlet is not available. The temporary adapter should be used only until a properly grounded outlet (figure A) can be installed by a qualified electrician. The green colored rigid ear, lug, or the like extending from the adapter must be connected to a permanent ground such as a properly grounded outlet box cover. Whenever the adapter is used, it must be held in place by a metal screw.

NOTE: In Canada, the use of a temporary adapter is not permitted by the Canadian Electrical Code

EXTENSION CORDS

Use only three-wire 14/3 or larger gauge approved extension cords that have three-prong grounding type plugs and three-pole receptacles that accept the appliance's plug. Replace or repair any damaged cords or plugs.

When servicing, refer to authorized person only. Use only identical replacement parts.

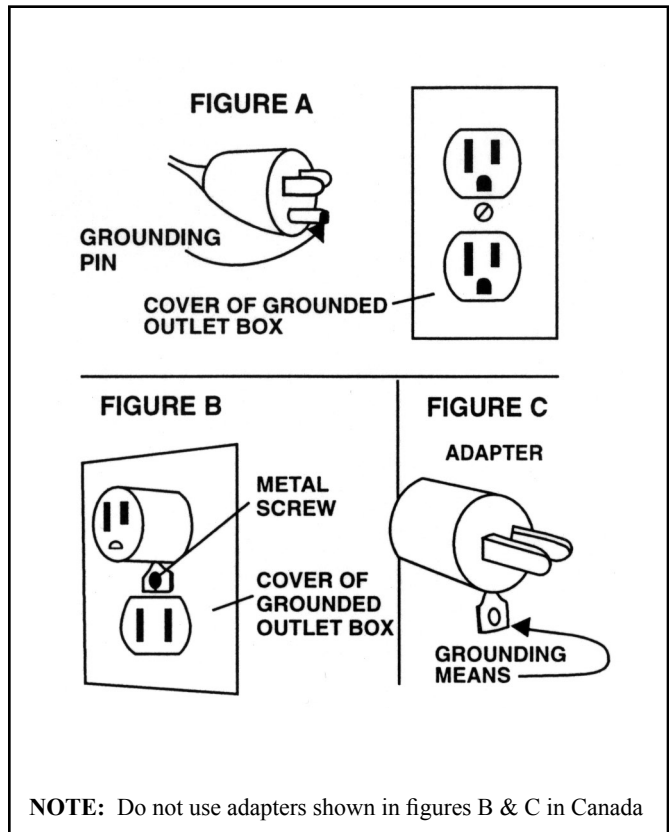

IMPORTANT SAFETY INSTRUCTIONS

When using an electrical appliance, basic precautions should always be followed, including the following:

READ ALL INSTRUCTIONS BEFORE USING THIS MACHINE

WARNING: To reduce the risk of fire, electric shock, or injury:

1. You must have training in the operation of this machine before using it.
2. Machines can cause an explosion when near flammable materials and vapors. Do not use this machine with or near fuels, grain dust, solvents, thinners, or other flammable materials.
3. Do not operate this machine unless it is completely assembled.
4. Do not use this unit for dry pick-up of dust or debris.
5. To prevent electric shock, always remove the electrical plug from the electrical outlet before doing any repairs or maintenance to this machine.
6. To prevent injury, always remove the electrical plug from the electrical outlet before leaving the machine.
7. Maintenance and repairs must be done by authorized personnel only.
8. Do not immerse. To reduce the risk of electrical shock, use only on carpet moistened by the cleaning process. Protect the machine from rain. Keep the machine in a dry building. Always clean the machine with a clean dry cloth.
9. Always use a three-wire electrical system connected to the electrical ground. For maximum protection against electrical shock, use a circuit that is protected by a ground fault circuit interrupter. Consult your electrical contractor.
10. To prevent damage to the power cord, do not move this machine over the power cord. Always lift the power cord over the machine. Do not pull or carry cord, use cord as a handle, close a door on cord, or pull cord around sharp edges or corners. Keep cord away from heated surfaces.
11. Make sure all switches are turned off before plugging or unplugging it power cord into/from a wall receptacle.
12. Do not use water that is hotter than 60°C (140°F).
13. To prevent damage to the solution system components do not store in freezing temperatures without proper maintenance.
14. Do not allow to be used as a toy. Close attention is necessary when used near children.
15. Do not use with damaged cord or plug. If the machine is not working as it should, has been dropped, damaged, left outdoors, or dropped into water, return it to a service center.
16. Do not unplug by pulling on cord. To unplug, grasp the plug, not the cord.
17. Do not handle the plug or machine with wet hands.
18. Do not put any object into openings. Do not use with any opening blocked. Keep free of dust, lint, hair and anything that may reduce the airflow.
19. Keep hair, loose clothing, fingers and all parts of body away from openings and moving parts.
20. Do not pick up anything that is burning or smoking, such as cigarettes, matches or hot ashes.
21. Use extra care when cleaning on stairs.

SAVE THESE INSTRUCTIONS

PREPARATION AND TRANSPORTATION

PRESTART-UP CHECKS

ACHIEVER 80/110 machines are very simple and easy to operate. Very little maintenance and service are required to keep your machine in top operating condition.

The following procedures are recommended to maintain the high level of performance expected from your machine. They are also intended to identify potential safety hazards and problems which could reduce the service life of the machine.

READ BEFORE TRANSPORTING OR OPERATING YOUR MACHINE:

1. Check **power cord**, **plug** and **strain relief** for worn or damaged insulation. Repair or replace if necessary.
2. Make sure the **drain valve** is closed (T-Handle pushed down). If the valve is left open, the vacuum is dramatically reduced and any recovered solution will drain out.
3. The **knob** for the **spool valve** is located on the lower back panel of the machine. During normal operation as a self-contained extractor this knob is turned toward **“machine” (horizontal position)**. It should be turned to the **“tool” position (vertical)** when a wand or other tool is being used.
4. Lock the **brush chassis** in the up position for storage or transport. This is done by pulling up on the **lift-handle** at the front of the machine, then resting the round lift stop behind the bracket.
5. Inspect the **vacuum head** and **brush** by tilting the machine backwards, allowing it to balance on the wheels and drain valve spout.
 - a) **Vacuum Head:** Check for any damage. Burrs on the contact surface may snag carpet fibers. Gouges, scratches and chipped areas can reduce vacuum performance.
 - b) **Brush:** Inspect for damaged or missing bristles, replace if necessary.

Return the machine to the upright position.

6. Check the **inlet strainer** for damage or debris. It is located at the bottom of the fresh water tank. Holes in the screen can allow contaminants to enter the pump resulting in costly repairs. A clogged strainer will reduce pump performance and may cause permanent damage.
7. Remove the clear dome on top of the recovery tank.
 - a) Inspect for damage to the **dome** and **gasket**. Dirt or debris on the gasket or sealing surface of the tank can cause a vacuum leak and reduce vacuum performance.
 - b) The **intake filter screen** at the vacuum hose connection should be clean of debris and checked periodically for any damage, replace if necessary.
 - c) Ensure that the **deflector shield** and **intake filter** are in their proper positions to prevent recovered water from entering the vacuum motor (blower).

Return the cover to its original position with the front lip seated under the retaining bracket.

YOUR MACHINE IS NOW READY FOR OPERATION.

TRANSPORTING

The ACHIEVER 80/110 is equipped with large diameter (10”) wheels for balance and ease of transporting. It is designed to be tilted back on the wheels and pushed or pulled. **The brush chassis should be locked in the up position any time the machine is in storage or being transported.**

The large diameter of the wheels permits you to pull the machine up stairs in the same manner you would use a hand truck. **Never go up or down stairs with recovered water or solution in the tanks.** Always empty the machine completely before transporting up or down stairs or in a vehicle.

When empty, the machine may be laid down on the side for transporting without damaging any of its components.

OPERATING PROCEDURES

The ACHIEVER 80/110 machines are the most “user friendly” self-contained extractors available. The following procedures are intended to describe and detail proper operation of your machine. Failure to follow these recommended procedures can reduce the machine’s performance and may result in damage to the machine.

1. **Vacuum the area to be cleaned.** Your machine will do a more thorough job if the loose dirt and debris are removed before the extraction process begins.
2. **Fill the fresh water tank** (lower tank) with water and Heavy Duty Carpet Extraction chemical. Hot water is recommended, but not required. Do not use water hotter than 60°C (140°F). Mix in chemicals according to the chemical manufacturer’s recommendations. For best results use Steamex Heavy Duty Carpet Cleaner.
3. Use of an extension cord is not recommended. However, if one is necessary, use only a **14 gauge** or larger cord. Smaller or inferior cords are dangerous and may cause damage to your machine.
4. After the machine is filled with solution, **connect the power cord plug to a 115 volt grounded wall socket.** See Grounding Instructions.
5. **Lower the floating brush chassis** using the lift handle located in the front of the machine. Lift the handle off the lift stop bracket and lower until the brush contacts the floor. Remember to always raise and lock the brush chassis for storage and transport.
6. **Turn the spool valve knob** (located on the back of the machine) **to the:**
 - a) **“Machine” (horizontal) position** for routine carpet extraction as a self-contained unit, or
 - b) Turn it in the **“Tool” (vertical)** position when using a wand or tool.
7. The **switch panel** is located on top of the handle and contains the following:
 - a) **Turn the vacuum switch on** to start the vacuum motor.
 - b) **Accessory only pump switch:** Do not turn on the accessory pump switch unless the spool valve knob is turned to the tool position.
8. **Pull backward during operation.** **DO NOT ATTEMPT TO OPERATE IN A FORWARD DIRECTION.** Position yourself behind the machine, grasp the handle and gently **lift up on the actuator bar.** Lifting the actuator bar activates the brush drive motor and the pump. Walk slowly backward to perform the cleaning process.
9. **Release the actuator bar approximately 6 inches before completing each pass.** The spray jets are located behind the vacuum head making it necessary to pull the machine a few inches further to pick up the last amount of solution dispensed onto the carpet.
10. **Tilt the machine back on the rear wheels and walk forward** to position the machine along side the previous pass (slightly overlapping).
11. As dirty solution is recovered, some foaming may be noted. Excessive foaming can be counteracted with liquid defoamer applied according to the chemical manufacturing directions. **Do not allow foam to rise into or near the dome.** Use defoamer or empty and flush the recovery tank.
12. To **drain the recovery tank**, place an empty bucket under the drain valve located on back of the machine. To open the drain valve pull the T-Handle up. Close the drain when the bucket is full or the recovery tank is empty. Dispose of the recovered water properly.
13. **If streaking occurs** after a period of operating time, this means the solution (fresh water) tank is near empty. Streaking is eliminated by adding more water and chemical solution to the tank.
14. To **drain the solution tank**, attach the small drain or “pump out” hose to the accessory quick connect on the back of the machine. Turn the spool valve knob to the “tool” position. Place the open end of the hose into a bucket and turn on the accessory pump switch. When empty, turn off the pump switch and remove the hose from the quick connect. Also return the spool valve knob to the “machine” position.
15. **After each use clean the dome, intake filter and gasket.** Do not reinstall the dome until the next use, this will allow the recovery tank to dry out.
16. **Raise the brush chassis** for storage.

SERVICING

ACHIEVER self-contained extractors are designed and manufactured to provide years of trouble free service with a minimum of maintenance and service. The following recommendations are intended to assist the operator and Service Technician in performing routine maintenance.

Failure to follow these recommendations can result in damage to your machine and diminished performance.

Warning: Always unplug your machine before performing any service. Severe personal injury could result if the electrical power is not disconnected.

1. Always follow through with the recommended prestart-up checks found in the Preparation and Transportation section of this manual.
 2. Store your machine in a dry, protected area with the brush chassis raised and locked in place. Do not expose this machine to rain, standing water or freezing temperatures.
 3. We recommend a good, thorough cleaning after each use. Clean the dome top, intake filter screen and recovery tank with fresh, clean water. Flush the fresh water tank and strainer periodically with clean water.
 4. After continuous or repeated use, the jet tips and strainer/check valves will need cleaning. Unplug the cord and empty the recovery and solution tanks. Tilt the machine backward allowing it to balance on the wheels and drain valve. Remove the jet caps shown in the brush chassis illustration and clean with white vinegar and a soft bristle brush. Remove the jet tip and strainer/check valve and soak it in vinegar until visible deposits are dissolved, then scrub with a soft bristle brush.
- Jet tips and strainer/check valves should be replaced once a year because they tend to erode under extended use. This can cause overuse of solution and possible streaking.

AN AUTHORIZED SERVICE CENTER SHOULD PERFORM THE FOLLOWING PROCEDURES

- 1. Drive Belt Adjustment and/or Replacement:** The cogged drive belt system rarely needs tightening, so if it becomes loose from wear, it is time to replace it. Follow this procedure:
 - a) Remove the two screws that attach the hanger bracket to the brush shroud. Then remove the thru-bolt from the brush chassis and lift handle. Remove the lift handle and lift stop.
 - b) Tilt the machine backward allowing it to balance on the wheels and drain valve. The brush chassis will remain on the floor exposing the brush drive belt and motor.
 - c) Loosen the two motor bracket mounting bracket mounting bolts with a 7/16" wrench. **DO NOT REMOVE THE BOLTS UNLESS YOU ARE REPLACING THE MOTOR.** Slide the motor away from the brush to tighten the belt or toward the brush for removal.
- 2. Pump Replacement:**
 - a) Remove the lift stop handle as described in the "Belt Drive" procedure (#1a).
 - b) Tilt the machine backward as described in the "Belt Drive" procedure (#1b)
 - c) Disconnect black wire (#2) and the white wire from the bridge rectifier (part #A130172). Also disconnect the ground wire (this will need to be respliced and reconnected to the ground wire on the brush motor when reassembling). Reference the electrical schematic.
 - d) Remove the two hoses from the pump. It is now fully exposed for replacement.
 - e) When reassembling after any repairs, make certain that all wire connections are properly plugged in and secure.
 - f) Make all solution hose connections secure.

Unlike a "V" type belt, the cogged belt is run with basically zero deflection. To test the belt tension, hold the belt between your thumb and forefinger and twist to the side. It should turn approximately 90° with little effort. If it twists more than 90°, retighten the belt.

3. Vacuum Blower Replacement:

- a) Remove the dome top and carefully turn the machine upside down.
- b) Remove the two hex bolts at the base of the black panel on the back of machine.
- c) Remove the wheels in order to get at the hex bolts in step (d). Shoulder bolts hold the wheels on.
- d) Then remove the six hex head bolts on both sides of blower chassis.
- e) Disconnect the two power leads and the ground wire coming through the back of the machine to the blower.
- f) Tip the blower and brush chassis away from the machine and carefully feed the vacuum hose down through the back of the machine.
- g) Then remove the three (3) bolts that hold the bracket for the blower. Remove the bracket.
- h) Release the blower from the bracket by removing the three bolts which hold them together.
- i) The blower can now be removed.
- j) When reassembling after any repairs, make certain that all wire connections are properly plugged in and secure.
- k) Avoid abrasive contact with sharp edges on the metal parts as injury can result.
- l) Make sure all vacuum hose connections are secure.

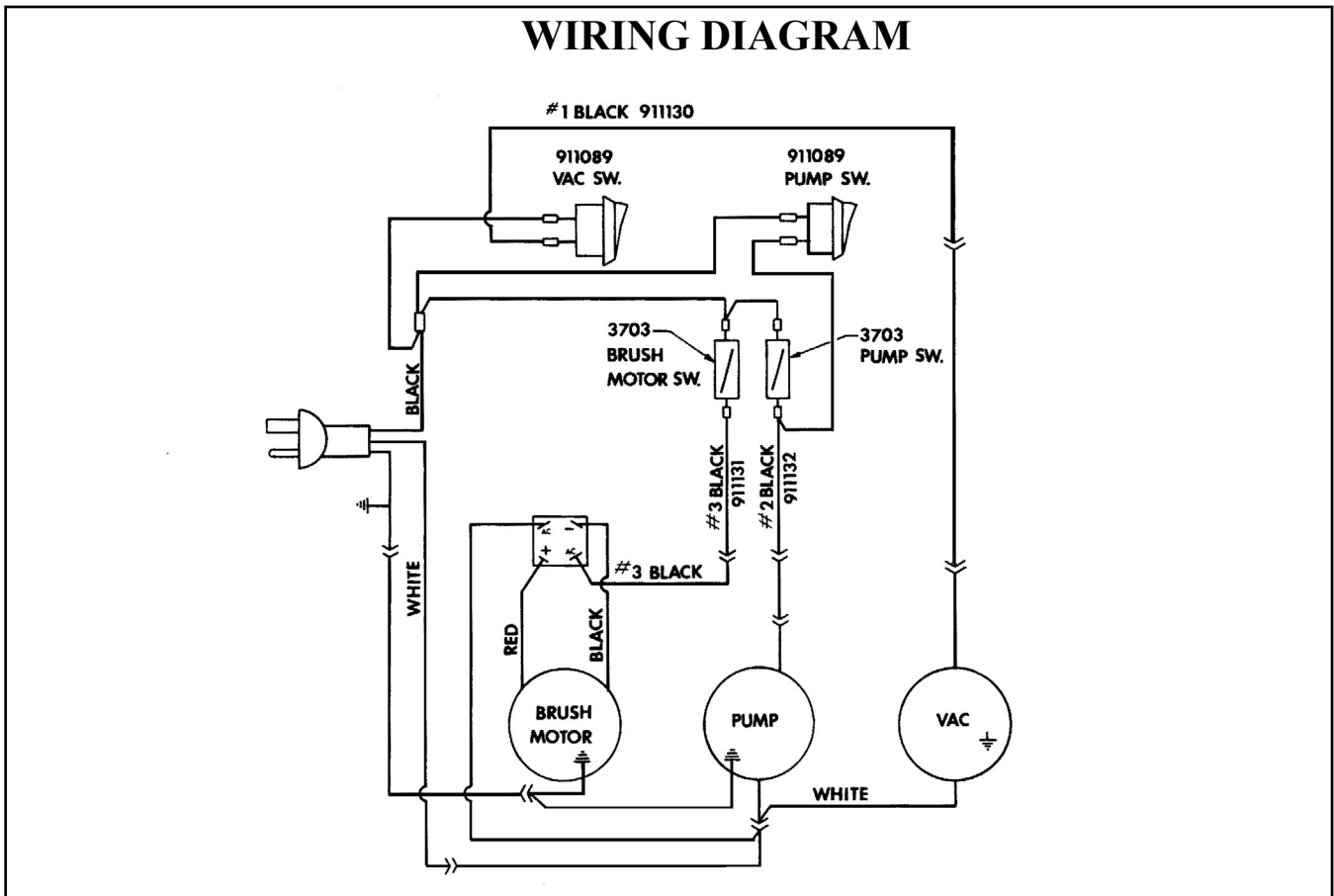

TANK & BLOWER

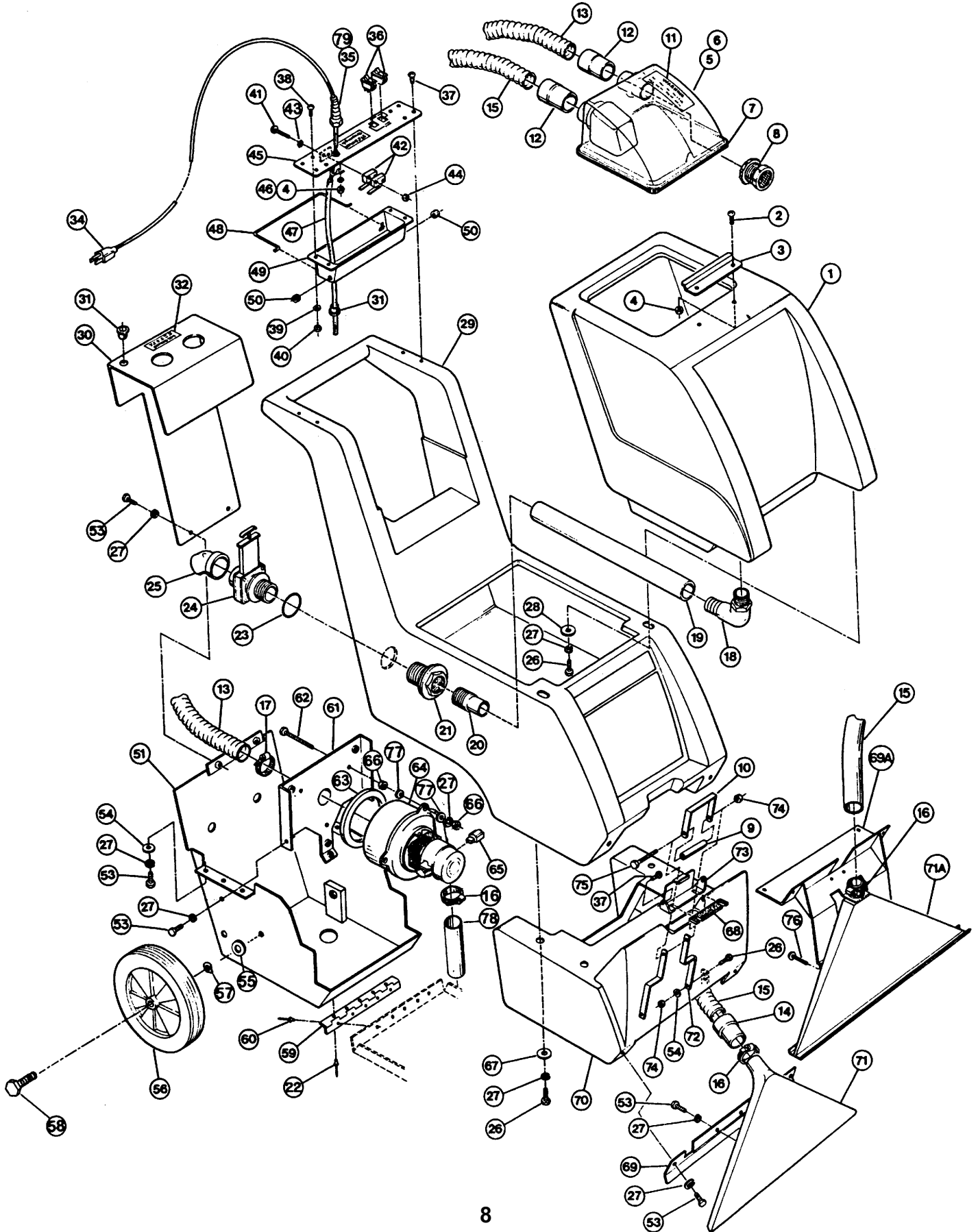

TANK & BLOWER

ITEM	PART NO.	DESCRIPTION	QTY.
1	208662	Recovery Tank 110	1
	208661	Recovery Tank 80	1
2	W191D1	Screw #10-24 x 3/4 RHP SS	2
3	217201	Dome Clasp	1
4	W106D	Nut #10-24 Hex SS	3
5	215005	Dome Assembly w/Gasket	1
6	212704	Dome Assembly w/o Gasket	1
7	213405	Dome Gasket	1
8	3685	Intake Filter (3732 Scr.; 3733 PVC)	1
9	A12999	Lift Stop	1
10	A12998	Lift Handle	1
11	D161C	Decal: Add Defoamer	1
12	3698	Cuff Hose	2
13	3694	Hose 1 1/2" x 33" (part of 3691)	1
14	3735	Cuff Hose	1
15	3695	Hose 1 1/2" x 62"	1
16	S611A	Hose Clamp	1
17	S216P	Hose Clamp	2
18	A13007	Adaptor 90° 110	1
	A13005	Adaptor Straight 80	1
19	A13122	Drain Hose 1 1/4" x 1.25'	1
20	A13006	Adaptor: Reducing	1
21	S102P	Thru the Hull Fitting w/Gasket & Nut	1
22	930008	Pop Rivet	5
23	S400P6	O Ring	1
24	S400PB	Drain Valve	1
	S400P2	Drain Valve Seal Kit	1
	S400P3	T-Handle	1
25	S400PB4	Drain Elbow 2"	1
26	W189D	Screw 1/4-20 x 3/4 HH CS SS	10
27	980002	Lockwasher Split 1/4"	24
28	W212D	Washer 5/16" Fender Zinc	2
29	208660	Main Body - Grey	1
	208663	Main Body - Black	1
30	3687	Back Plate	1
31	3739	Snap Bushing	2
32	D167C	Decal: Warning Disconnect	1
34	908073	Power Cord 50'	1
35	A13020	Strain Relief	1
36	911089	Switch Rocker	2
37	W136D1	Screw #8 x 1/2" THP SMS B/O	6
38	W387D	Screw #8-32 x 3/8 RHP M/S B/O	4
39	980026	Washer #8 Int. Tooth	5
40	W143D	Nut: Hex #8-32 SS	4

ITEM	PART NO.	DESCRIPTION	QTY.
41	W317D	Screw #4-40 x 1-1/4" PHP MS SS	2
42	3703	Switch - Momentary	2
43	W307D	Washer #4 Ext Tooth	2
44	W385D	Nut: #4-40 Hex w/Nyloc	2
45	3675	Switch Plate	1
46	980015	Washer #10 Ext Tooth	1
47	3716	Sleeve: Wiring	6"
48	3799	Actuator Bar	1
49	3686	Switch Enclosure	1
50	3710	Grommet	2
51	C12995	Chassis	1
53	W169D	Screw 1/4-20 x 1/2" HH CS SS	15
54	W104D	Washer 1/4" Flat SS	9
55	980005	Washer 1/2" Wave	2
56	229750	Wheel	2
57	509820	Washer: Fibre	2
58	960031	Shoulder Bolt	2
59	A129671	Hinge	1
60	W363D	Pop Rivet	7
61	C12996	Bracket: Blower Mounting	1
62	W362D	Bolt 1/4-20 x 4 1/2" HH	3
63	603473	Gasket Blower (effective 11/00)	1
64	A13504	Blower 3-Stage 115V - 110	1
	215201	Blower 2-Stage 115V - 80 (eff.01/01)	1
	S818N	Grounding Terminal for 215201	
	S589P	Blower 2-Stage 230V - 80	1
	3738	Blower 3-Stage 230V - 110	1
65	210901	Carbon Brush for A13504 Motor	2
	210906	Carbon Brush for 215201 Motor	2
	210904	Carbon Brush for all 230V	2
66	920004	Nut 1/4-20 Hex SS	7
67	W311D	Washer 1/4" Fender	6
68	213403	Gasket: Lift Bracket (S791N1)	1
69	A13439	Bracket: Vac Head	1
70	C13118	Shroud	1
71	C13382	Head: Vacuum	1
72	B13000	Lift Bar	2
73	B13126	Hanger Bracket	1
74	920011	Nut 1/4-20 Nyloc	3
75	W340D	Screw 1/4-20 x 3 3/4 HH SC	1
77	980004	Washer 1/4" Flat	6
78	S209P	Hose: Exhaust 6"	1
79	920616	Nut 1/2 NPT	1

WATER CARRYING AND BRUSH CHASSIS

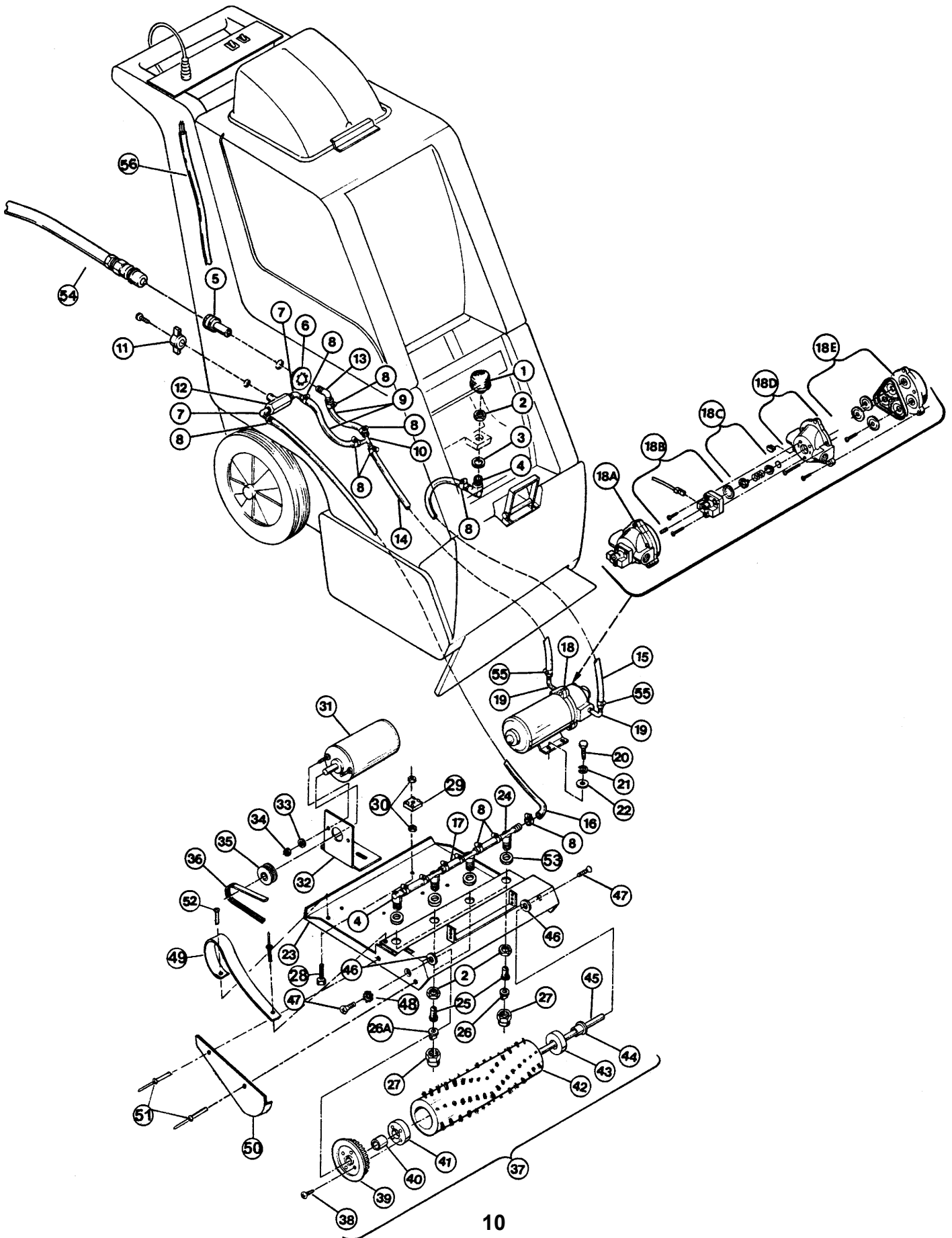

WATER CARRYING AND BRUSH CHASSIS

Achiever 80 & 110

ITEM	PART NO.	DESCRIPTION	QTY.
1	S626P	Strainer	1
2	W166D	Brass: Jam Nut	5
3	S372P	Washer: Nylon	1
4	211310	90° Jet Body 3/8	2
5	203308	Quick connect 1/4 Female	1
6	920620	Nut, .875 Stud	1
7	3770	Elbow: Barb 1/8 to 3/8	2
8	202050	Clamp: Hose	14
9	S250P	Hose (Order 6")	2
10	3766	Tee: Barb 3/8 Nylon	1
11	A13151	Knob	1
12	3824	Spool Valve w/Knob	1
13	3771	Elbow: Barb 1/4 to 3/8	1
14	S250P	Hose (Order 36")	1
15	S250P	Hose (Order 36")	1
16	S250P	Hose (Order 36")	1
17	S250P	Hose (Order 6")	3
18	3785V	Pump: 100 PSI 115V	1
	3821V	Pump: 100 PSI 220V	1
18A	204557	Pump Head Complete	1
18B	911112	Kit: Pump Switch	1
18C	3787	Kit: Check Valve	1
18D	3786	Kit: Upper Housing	1
18E	202701	NLA	1
19	3765	Elbow: Barb 3/8	2
20	W169D	Screw 1/4-20 x 1/2 HH MS	6
21	980002	Washer 1/4" Lock	6
22	W104D	Washer 1/4" Flat	6
23	C12988	Chassis: Brush	1
24	211309	Tee: Jet Body	3
25	S280P	Strainer/Check Valve: Brass	4
26	S962P	Jet Tip (8002) Note: 2 Outside Jet Tips	2
26A	A13013	Jet Tip (11002) Note: 2 Inside Jet Tips	2

ITEM	PART NO.	DESCRIPTION	QTY.
27	211501	Jet Cap	4
28	W205D	Screw #8-32 x 1" Nylon M/S	1
29	A13445	Rectifier	1
30	920617	Nut #8-32 Hex Nylon	2
31	A13017	Motor: Brush Drive 115V	1
	3760	Motor: Brush Drive 220V	1
32	200870	Bracket: Brush Motor	1
33	W124D	Washer: Lock #10 Int Tooth	2
34	W329D	Nut #10-32 Hex	2
35	3719	Cog: Drive Motor	1
36	3723	Belt: Drive Brush	1
37	7560	Brush Assembly	1
38	962062	Screw #6 x 3/4" SMS	4
39	3718	Cog: Brush	1
40	3677	Bearing: Rulon	1
41	3722	Insert: Drive Brush	1
42	3689	Brush	1
43	3721	Insert: End Brush	1
44	A13084	Bearing: Rulon	1
45	A12954	Brush Shaft	1
46	980612	Washer: Nylon	2
47	W353D	Screw 1/4-20 FHP MS SS w/Nylon	2
48	980032	Washer 1/4" FH Lock	2
49	213603	Splash Guard	1
50	213602	Belt Guard	1
51	W363D	Pop Rivet	3
52	W171D	Screw 6-32 x 1/4 RHP MS	1
53	218206	Spacer - Spray Jets	4
54	F920W	Pump Out Hose	1
55	S453P	Clamp-Hose	2
56	9600	Wiring Harness Assembly	1

SSS SELF-CONTAINED EXTRACTOR, ACHIEVER 80 & 110 LIMITED WARRANTY

The SSS Self-Contained Extractors, Achiever 80 & 110 have been manufactured, tested and inspected in accordance with specific engineering requirements, and is WARRANTED by the manufacturer to be free from defects in workmanship and materials.

This warranty is, however, subject to the following qualifications, conditions and limitations which are set forth to provide you and all users of the SSS Achiever 80 & 110 with information concerning the duration, extent, availability and applicability of this Limited Warranty, the procedure to be taken to obtain its performance and other information concerning the manufacturer's warranty policy.

1. TO WHOM EXTENDED AND DURATION OF ITEMS COVERED

This warranty extends to the original consumer purchaser from the date it was purchased and for the items and periods as follows:

Five (5) years parts, one (1) year labor - Polyethylene Tanks

One (1) year parts & labor - All other components unless excluded below.

2. PARTS NOT COVERED BY WARRANTY

Certain parts of the SSS Achiever 80 & 110 require replacement in the ordinary course of use due to normal wear by reason of their characteristics. This warranty does not cover the following normal wear items:

<u>Part Number</u>	<u>Part Name</u>
908073	Cord Assembly
209750	Wheel
S962P	Jet Tip
A13013	Jet Tip
3723	Belt
3689	Brush
3801	Brush
210901	Carbon Brush
210906	Carbon Brush
210904	Carbon Brush
3685	Intake Filter
S626P	Strainer
S280P	Strainer/Check Valve
F920W	Pump Out Hose

3. EXCEPTIONS AND EXCLUSIONS FROM WARRANTY

The SSS Achiever 80 & 110 is required to be used on electric current as indicated on the nameplate. Otherwise damage, defects, malfunctions or other failures of the SSS Achiever 80 & 110 arising from use on electric current not as indicated are excepted and excluded from this warranty.

Defects, malfunctions, failure or damage of the SSS Achiever 80 & 110 caused by improper, unreasonable or negligent use or abuse while in the possession of the consumer are likewise excluded from this warranty.

If repair is done on your SSS Achiever 80 & 110 by anyone other than those below designated as authorized to perform such work without first having obtained factory instructions, the manufacturer, at its sole option, may determine that this warranty will not apply and that reimbursement for such repair will not be made because of the failure to comply with such factory specified instructions.

4. PROCEDURE TO BE TAKEN TO OBTAIN PERFORMANCE OF WARRANTY

To secure repair of the SSS Achiever 80 & 110 or any warranted parts under this warranty, the following procedure should be taken: The inoperative SSS Achiever 80 & 110 or warranted parts, together with satisfactory evidence of the purchase date, must be delivered with shipping and delivery charges prepaid to the Dealer from whom purchased.

If you are unable to locate the Dealer, you may write or otherwise communicate with **Triple S, 2 Executive Park Drive, Billerica, MA 01862** for instructions before repair service is performed by anyone else. In such event Triple S will provide either the location of a closely available Triple S Distributor Service Department or other factory instructions.

Upon compliance with the above procedure, all warranted defects will be repaired, at no additional charge or costs to the consumer, and the repaired product returned to the consumer, with all shipping and delivery charges prepaid.

In following the procedures above set forth PLEASE MAKE CERTAIN to state the Triple S model, type and serial number as shown on the name plate of the SSS Achiever 80 & 110.

REPLACEMENT

In the event of the defect, malfunction or failure of your SSS Achiever 80 & 110 or any warranted part to conform with this warranty, the manufacturer may at its sole option and own expense, replace the SSS Achiever 80 & 110 or any warranted part with another new identical or reasonably equivalent model or part in lieu of repairing the defect.

5. NO REFUND OF PURCHASE PRICE

Triple S will not, as a matter of its warranty policy, refund the consumer's purchase price.

6. WARRANTY REGISTRATION CARD FOR YOUR SSS ACHIEVER 80 & 110 AND REQUESTS FOR INFORMATION

Please fill out the warranty registration card accompanying your SSS Achiever 80 & 110, giving complete information as requested on the card, and return to Triple S.

This warranty is in lieu of all other expressed or implied warranties.

